

SCHEMA PRODOTTO

SUBPRESSES FOR CORE PUNCHING DURING FORGING

APS
**6000/5000/4500/4000/3200/
2800**

Condition: New
Code: ZZAF003
Manufacturer: FPM GROUP

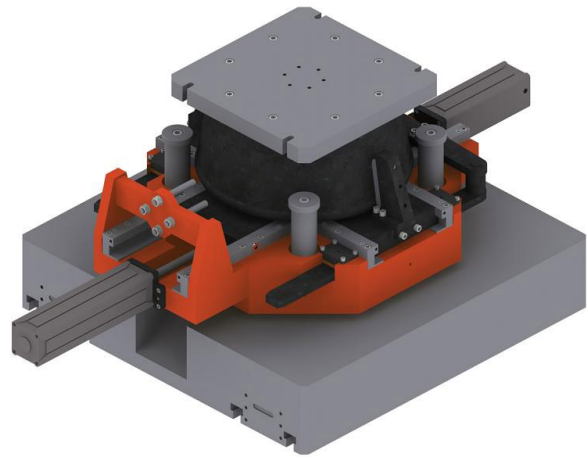

SUBPRESS FOR HOT BRASS AND ALUMINIUM FORGING, FOR VERTICAL CORING TYPE "BELL" model APS 4000

Sub press "bell" with 4 orthogonal movable sectors max. stroke 140 mm.

Automatic lubrication.

Bell external diameter 760 mm.

Semi candle incorporated into the base.

Stroke of the front dieholder sector 250 mm.

Stroke of the pinholder sector 130 mm.

Pneumatic opening and lockup of the front dieholder sector and pinholder sector.

Back dieholder stroke 400 mm.

Pneumatic opening and lockup of the back dieholder sector.

Automatic ejection of the piece down from above.

Max. dimensions of the dies 215x220x100 +10 mm.

Max dimension upper drilling pin diameter 100 mm.

Max dimension lower drilling pin 130 mm (extractable from the top).

Max dimension horizontal coring pins diameter 80 mm.